

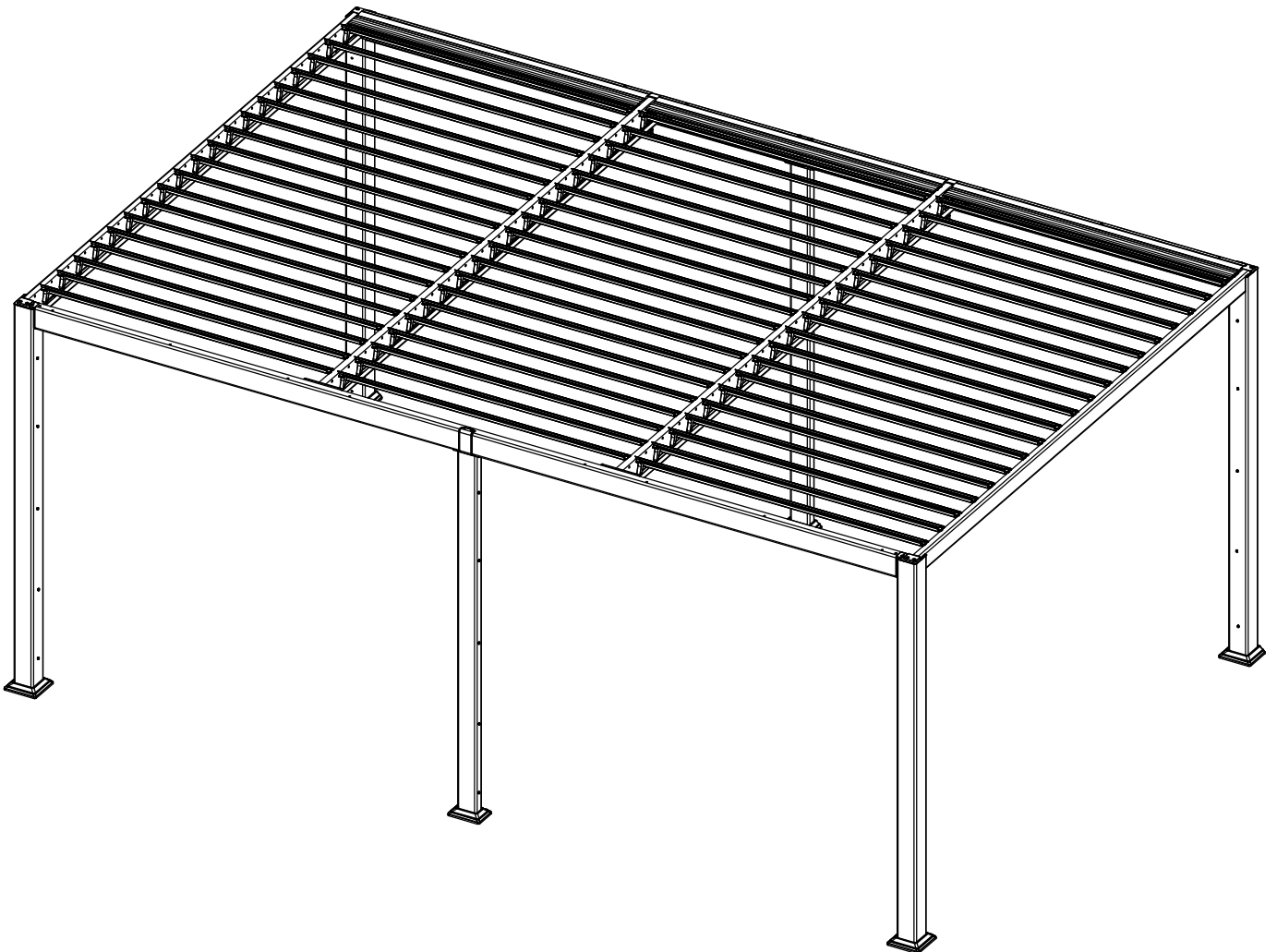

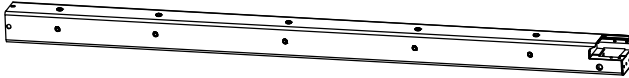







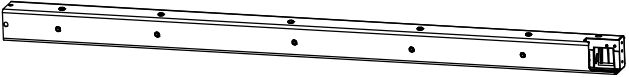















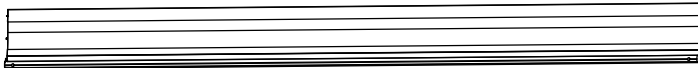



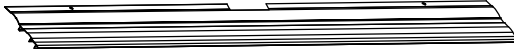

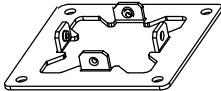
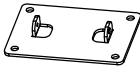
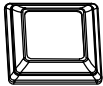
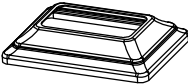
IM FOR GAL102

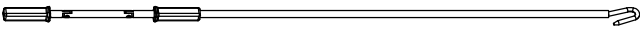
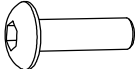
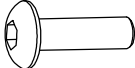
5.4*3.5*2.3M

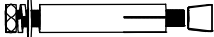
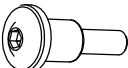

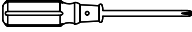
REF	PCE	PIECE		QTY	DIM
	A1			2	
	A2			2	
	A3			2	
	B1			2	
	B2			2	
	C1			1	
	C2			1	
	D			1	
	D1			1	
	F			114	
	G			2	
	G1			1	
	H			4	
	H1			2	
	J			4	

REF	PCE	PIECE	QTY	DIM
	J1		2	
	L		3	
	M		2	
	R		1	
	S1	 M6*15	34+2	
	S2	 M8*20	44+2	
	S3	 M4*18	3	
	S4		12+1	
	S5		2	
	T1		2	
	T2		1	
	T3		1	
		 Silicone neutral glass glue, purchased by customers		

STEP 01

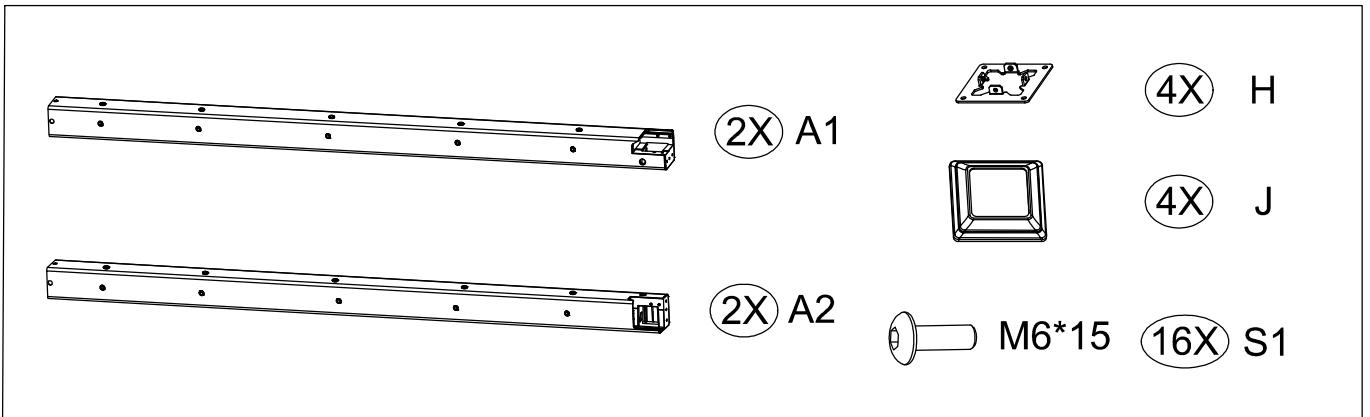
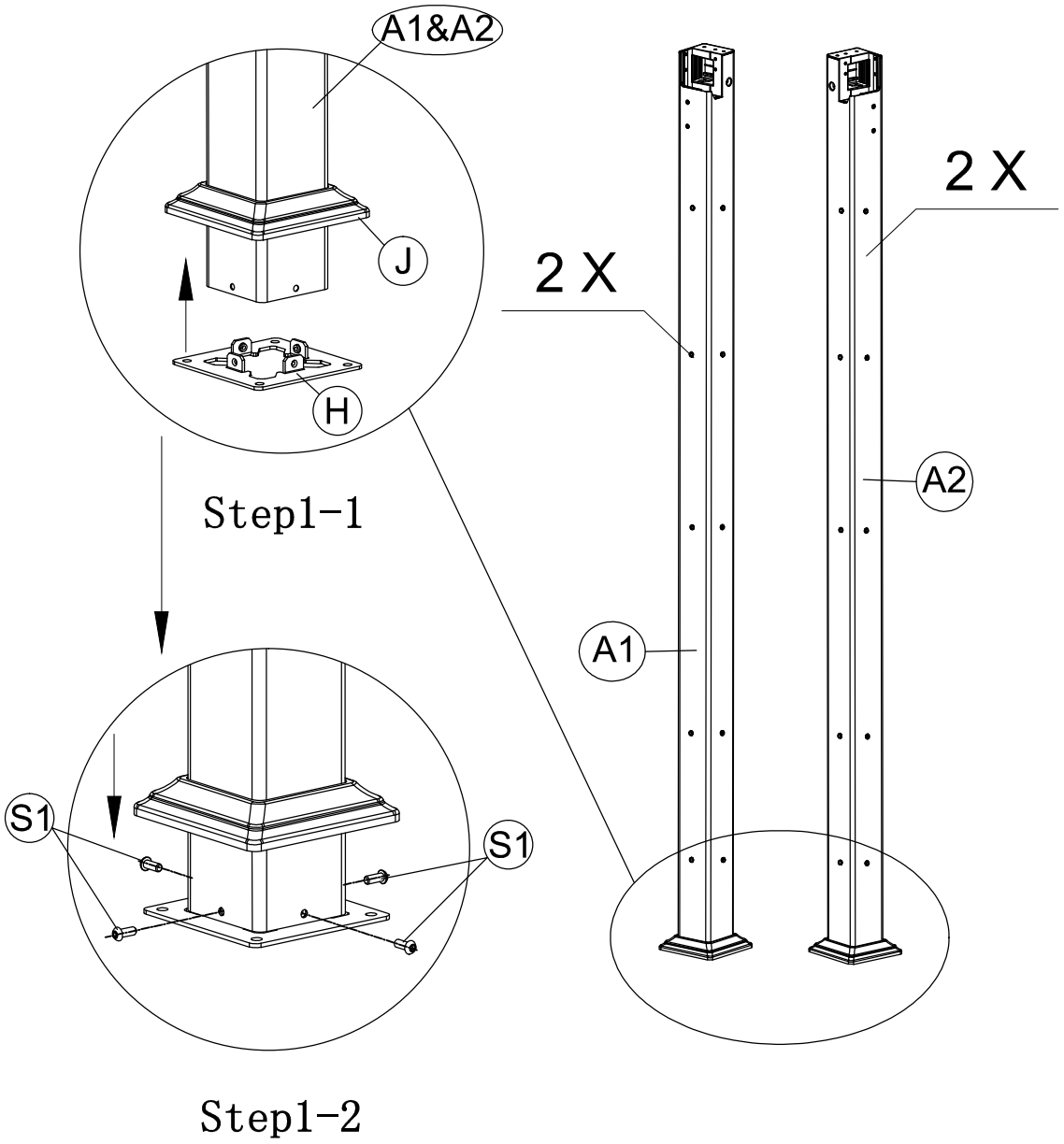

STEP 02

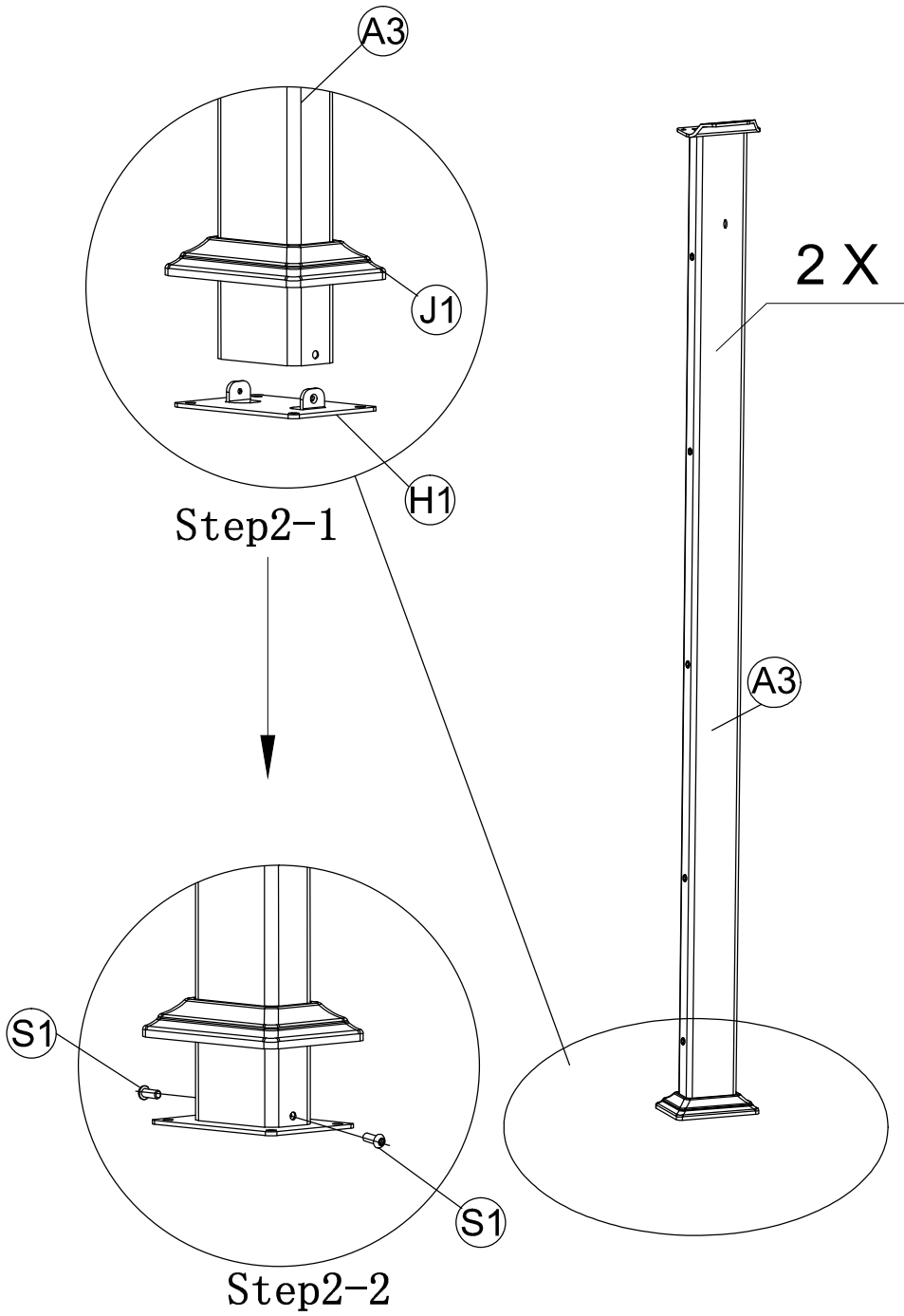

- | | | | | |
|--|---------|---------|---------|---------|
| | (2X) A3 | | (2X) H1 | |
| | M6*15 | (4X) S1 | | (2X) J1 |

STEP 03

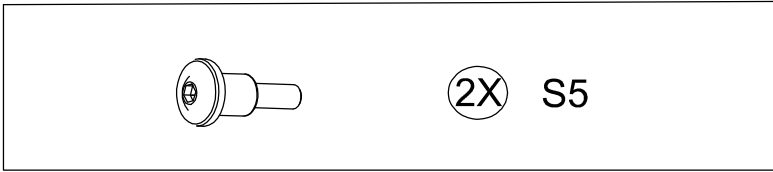
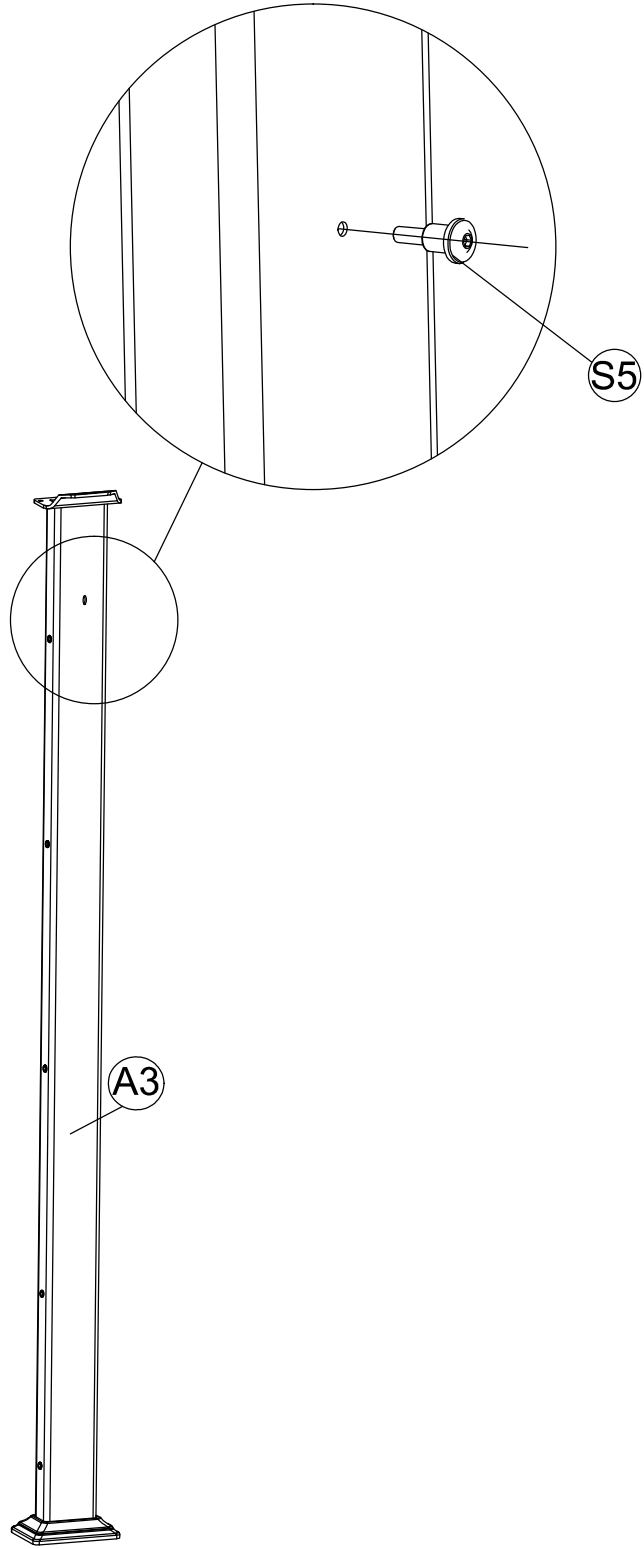

STEP 04

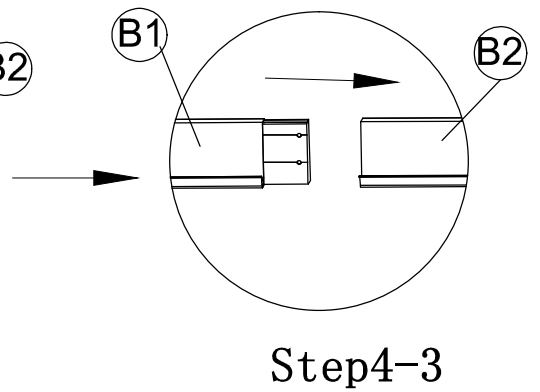
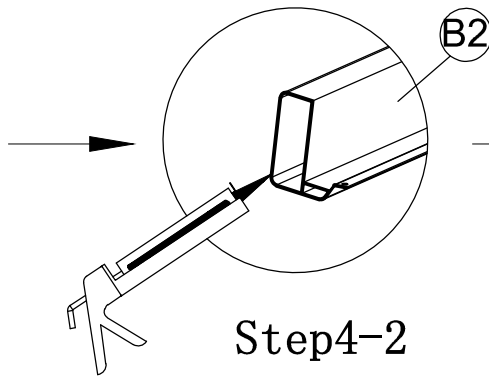
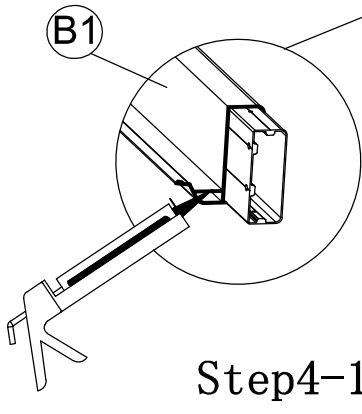
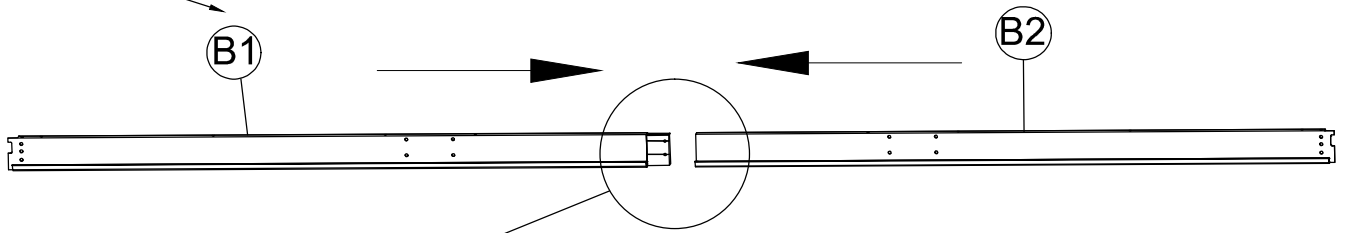

STEP 05

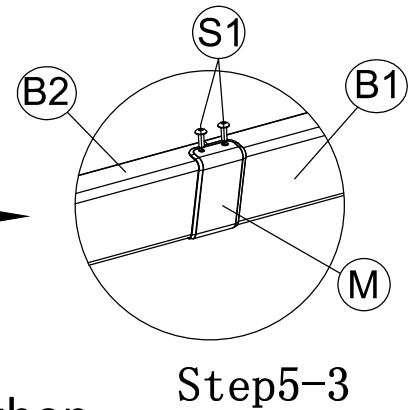
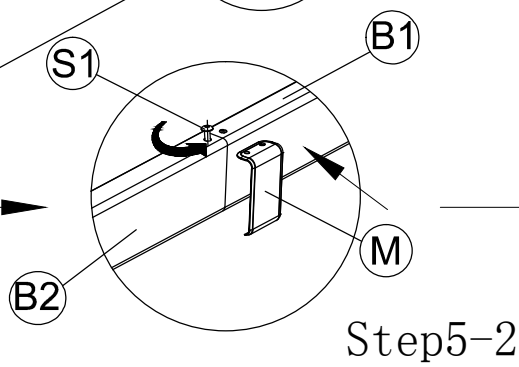
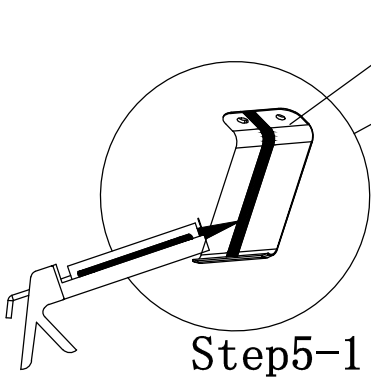
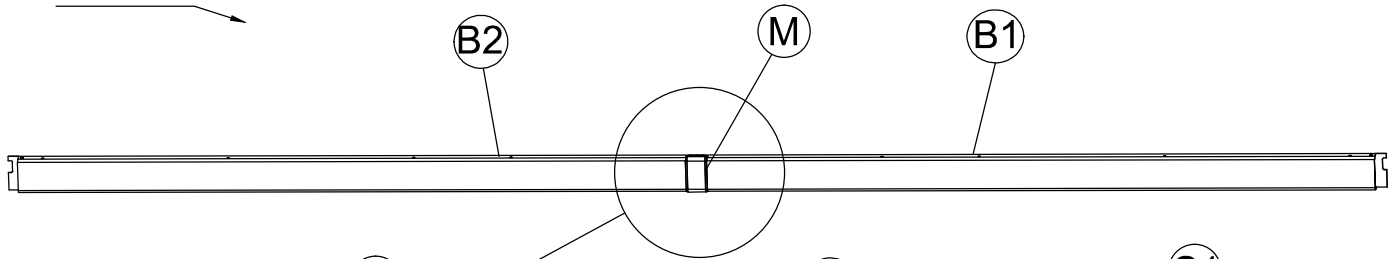

Take out part (S1) first, then assemble part (M)

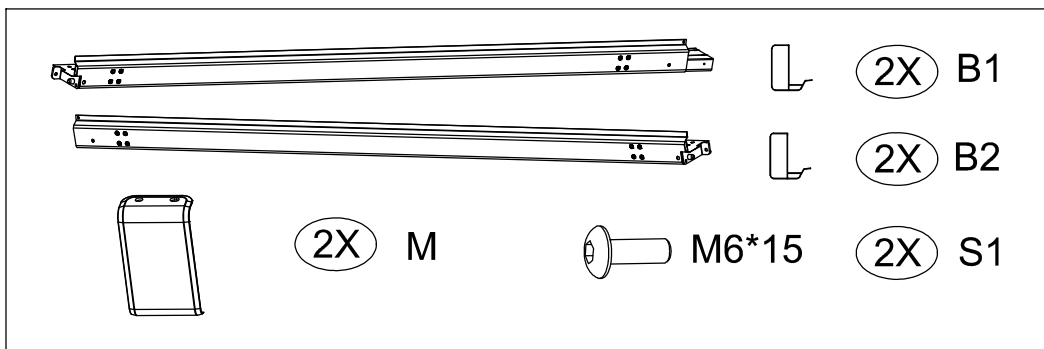

STEP 05

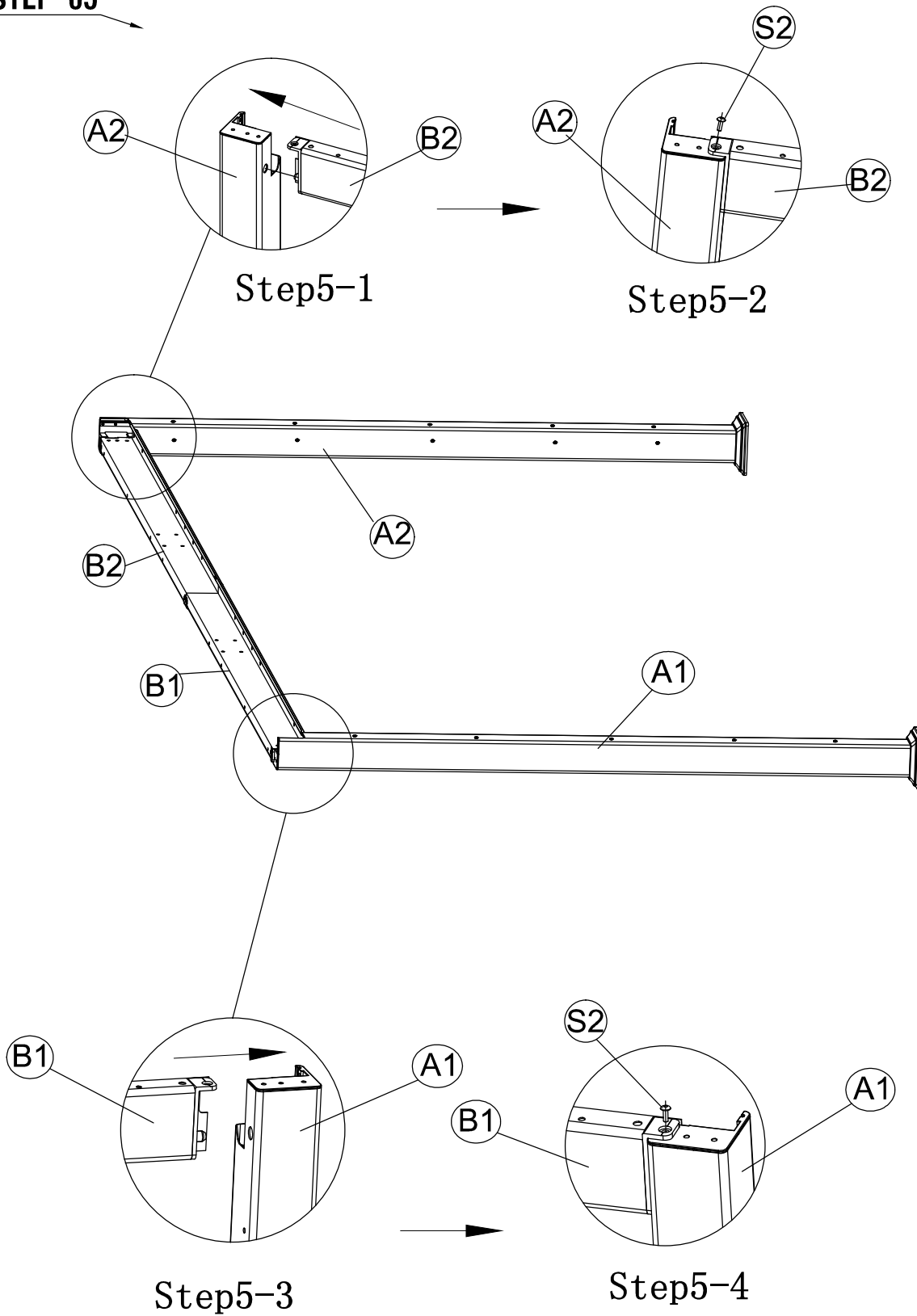

	M8*20	(2X)	S2
---	-------	------	----

STEP 06

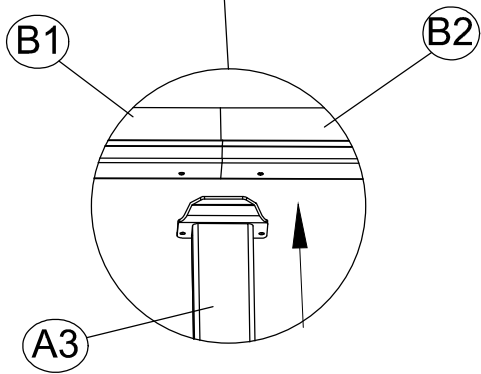
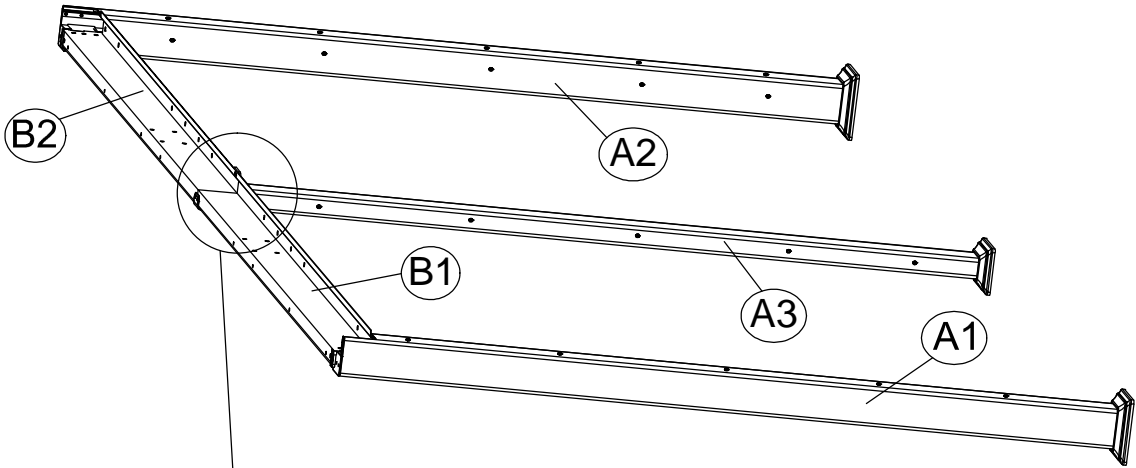

Step6-1

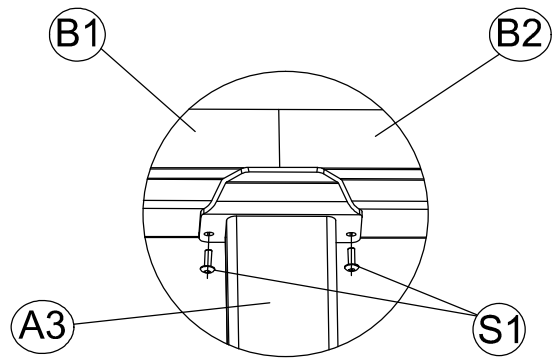

Step6-2

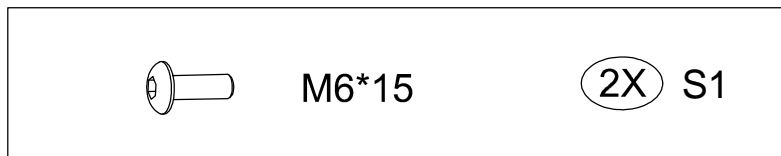

STEP 07

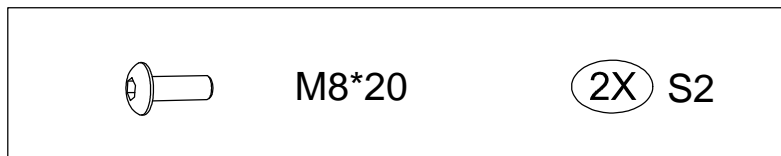
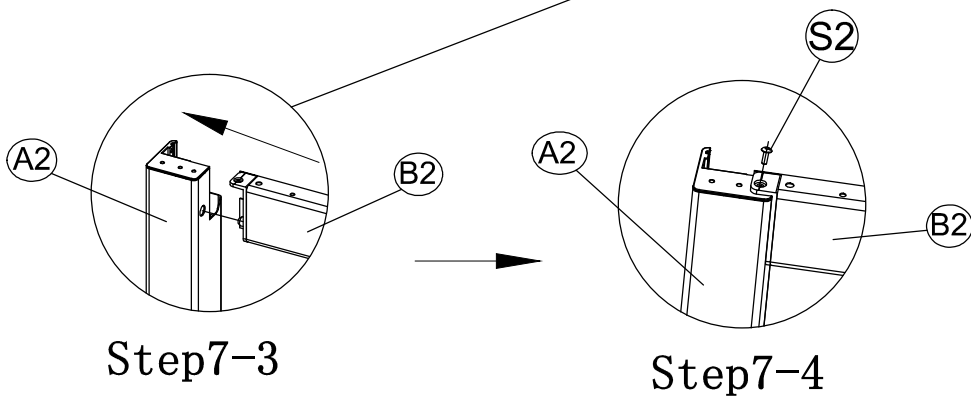
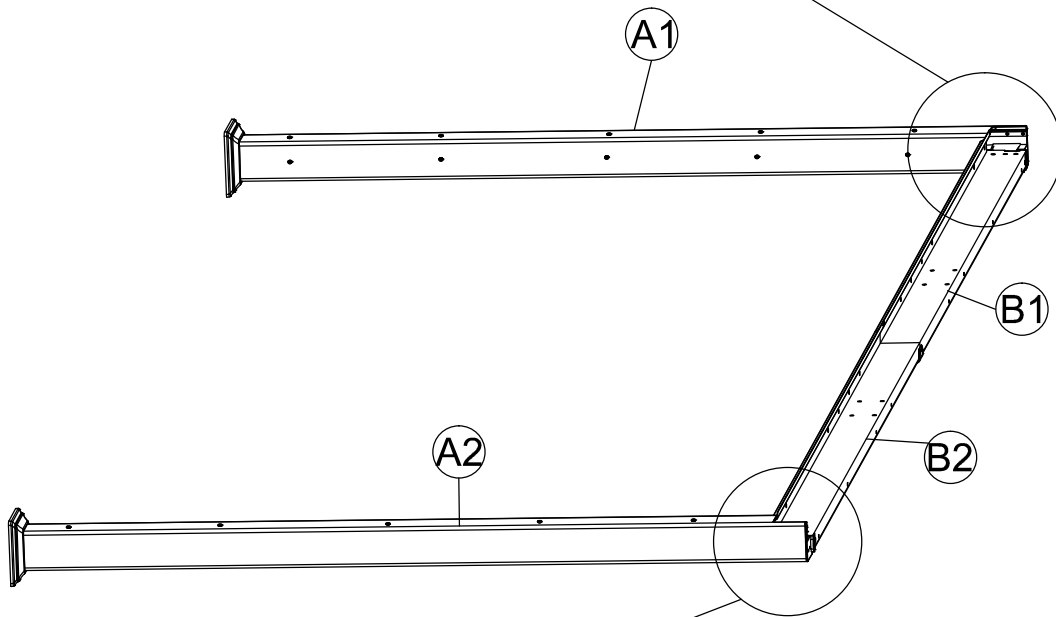
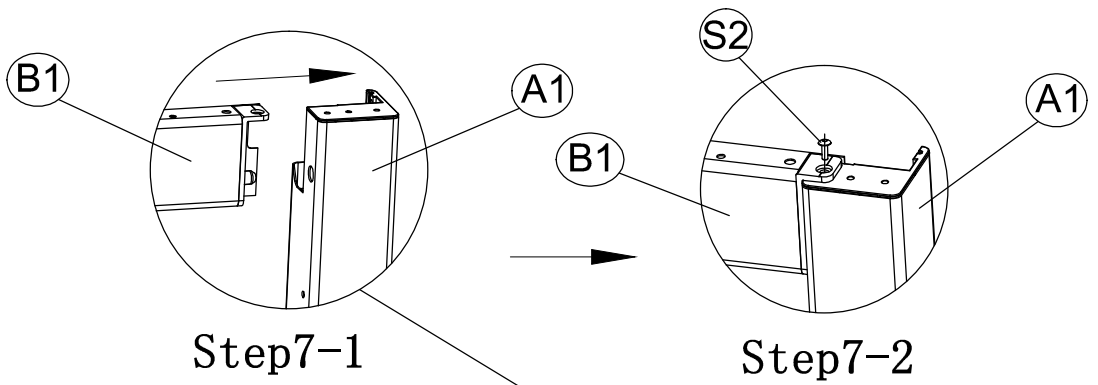

STEP 08

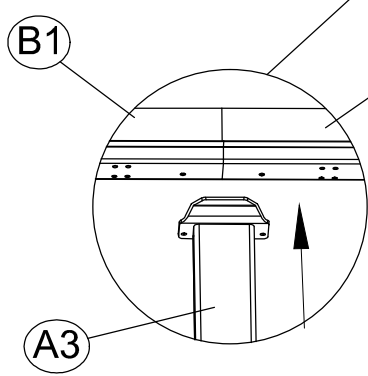
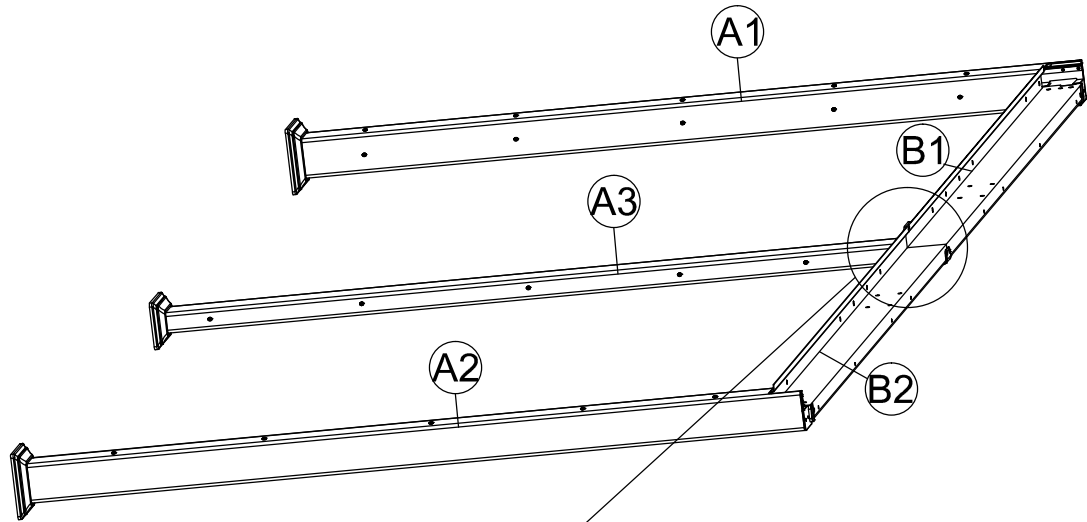

Step8-1

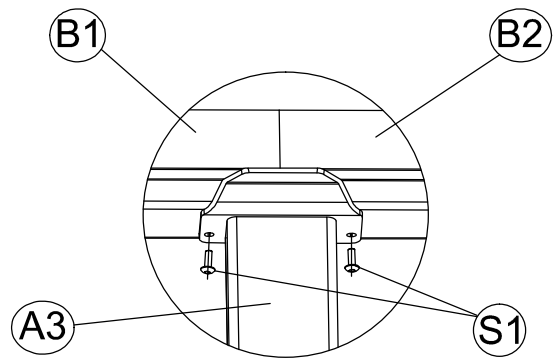
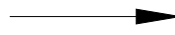

Step8-2

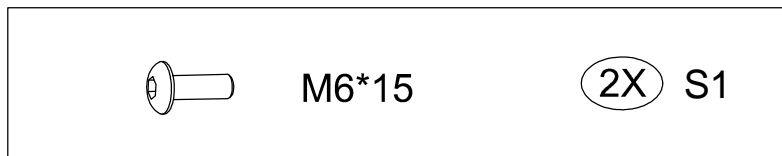

STEP 09

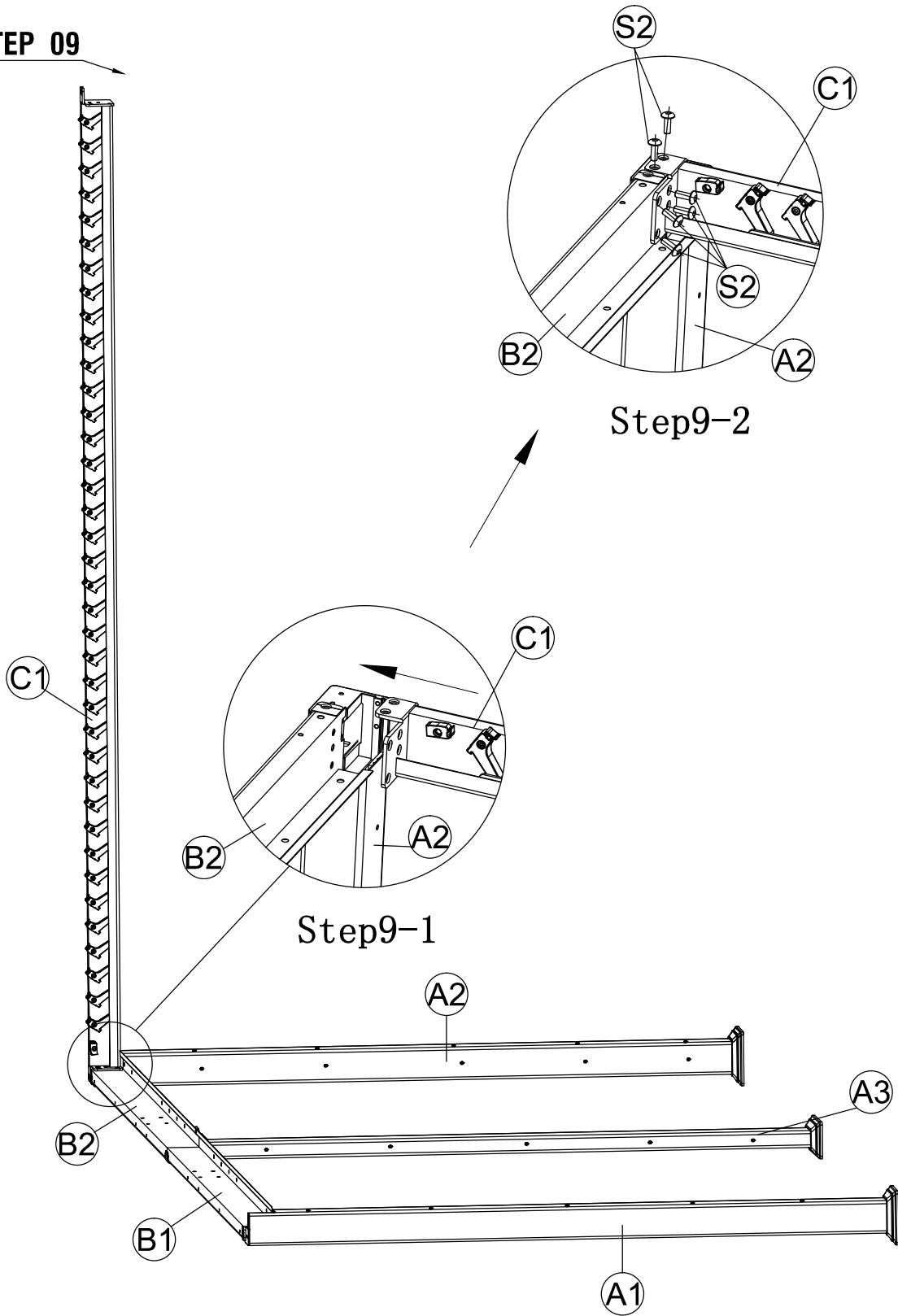

		1X C1
	M8*20	6X S2

STEP 10

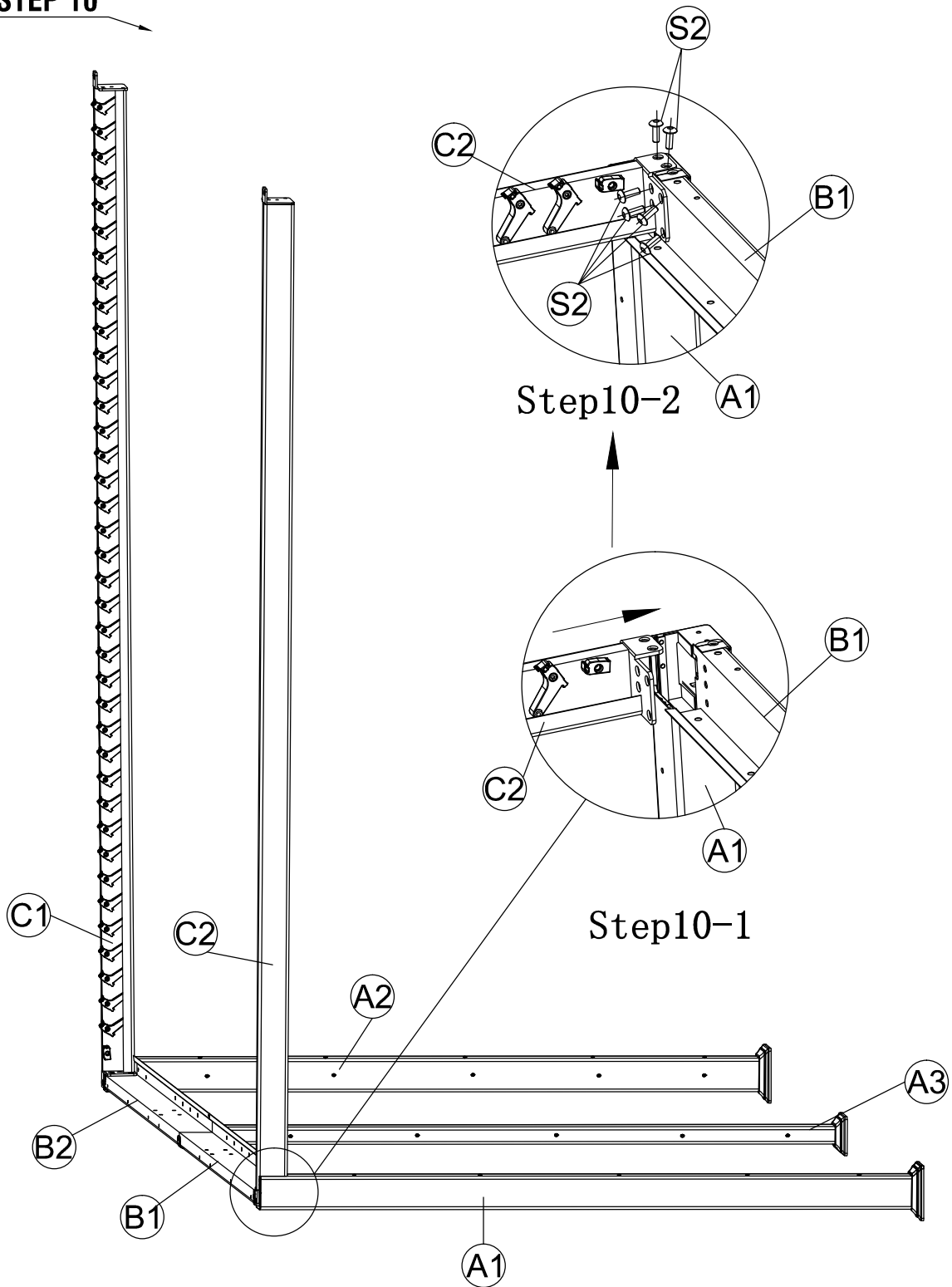

	⌒	(1X) C2
	M8*20	(6X) S2

STEP 11

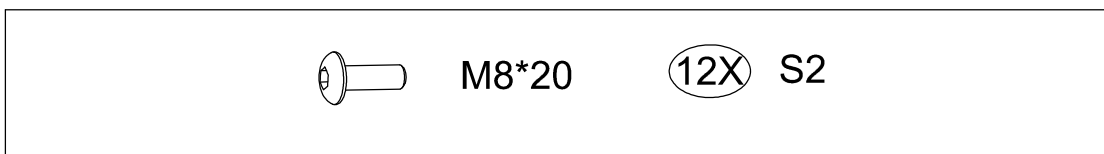
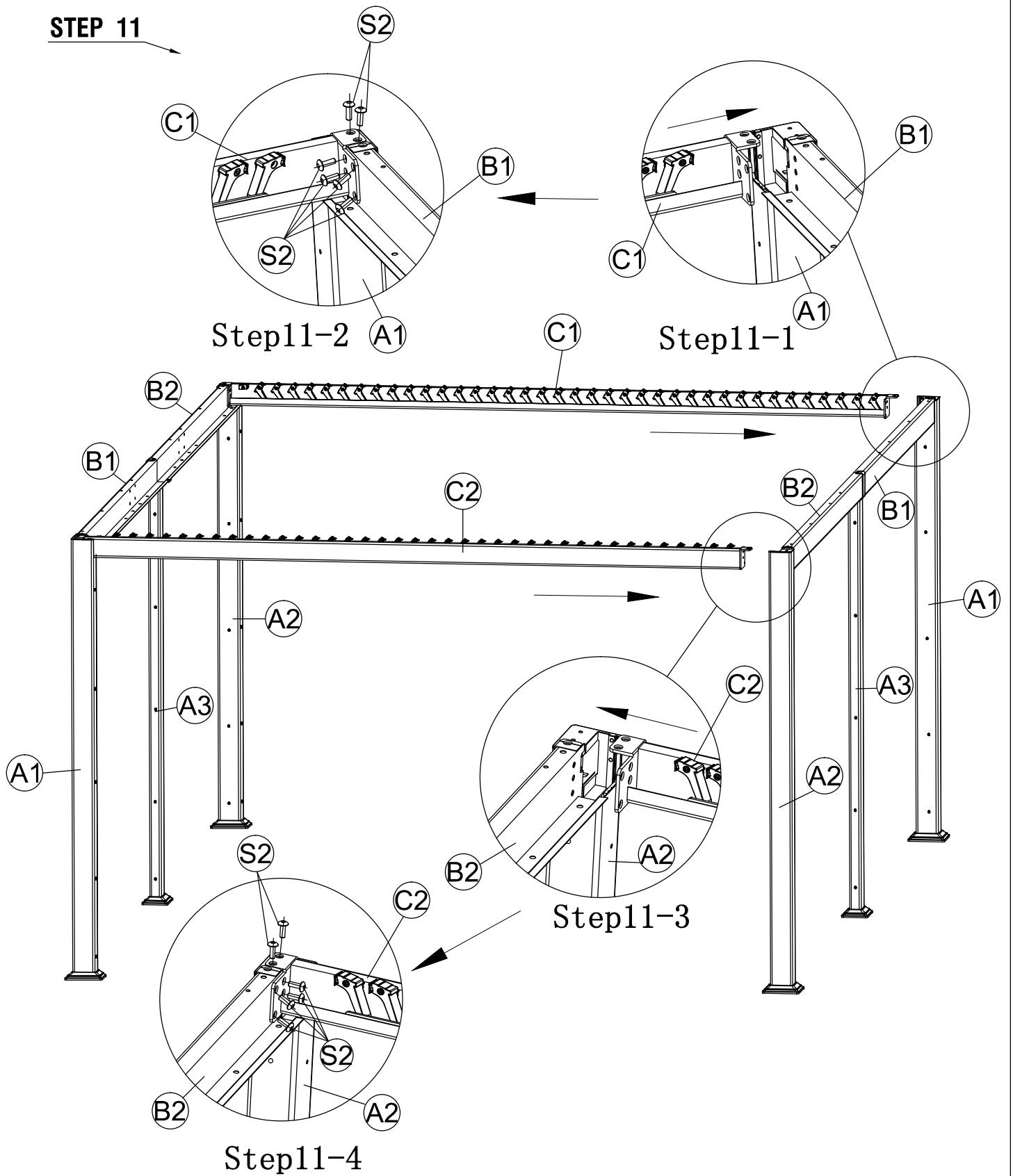

STEP 12

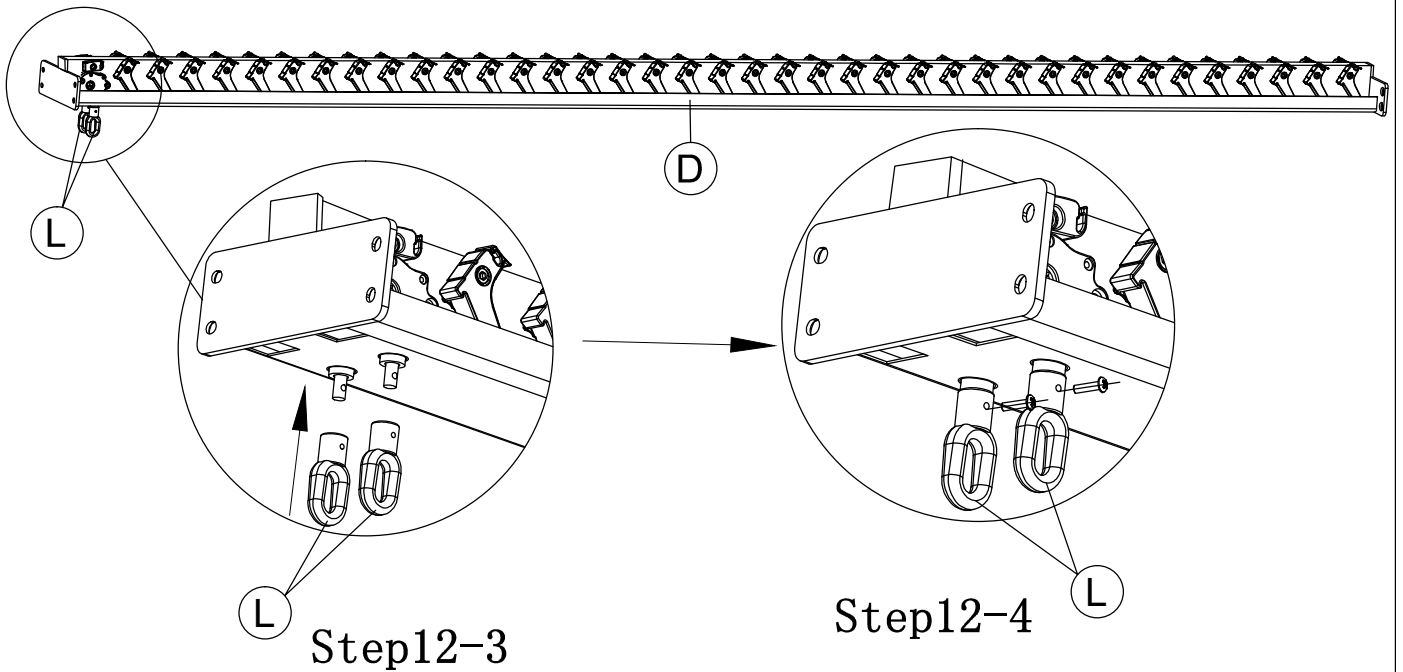
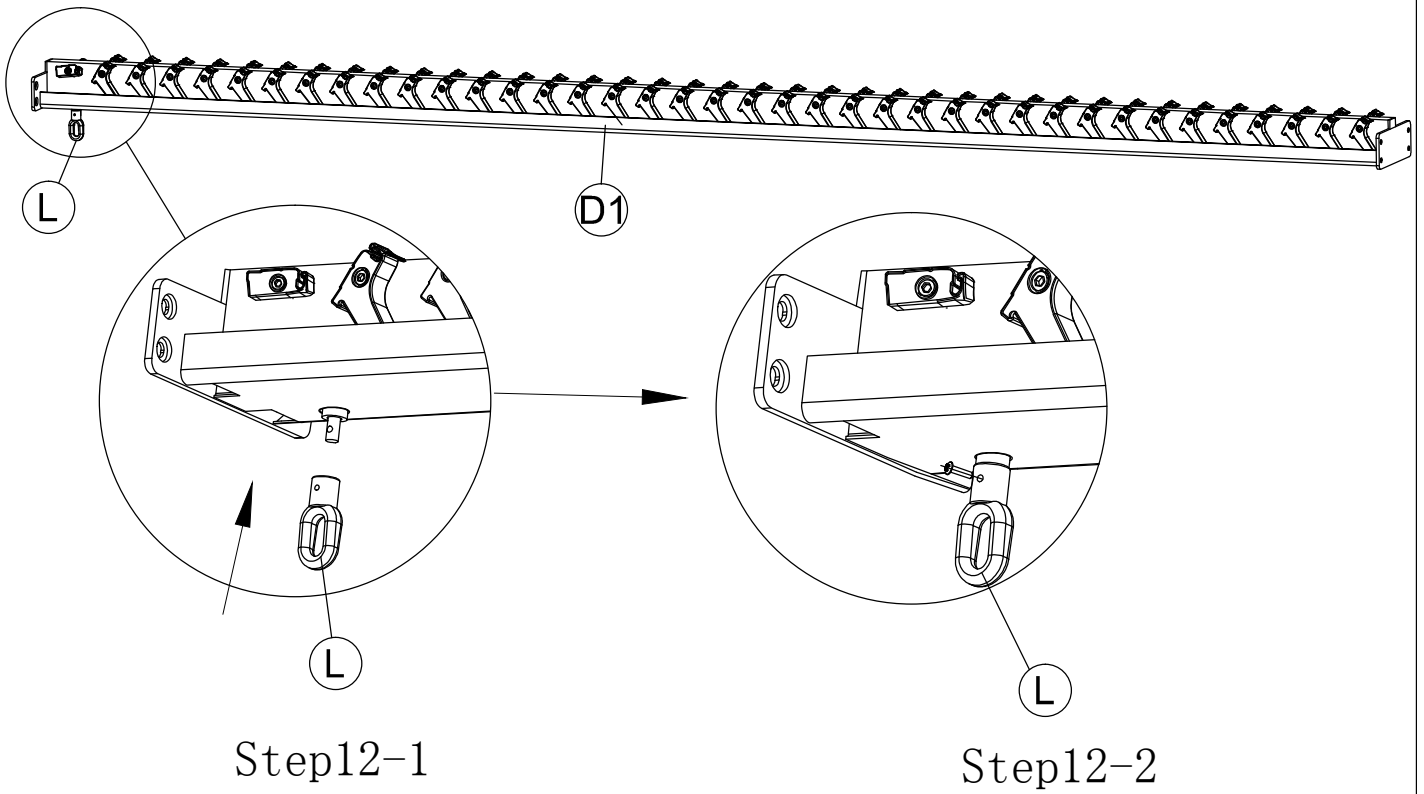

		(1X)	D1
		(1X)	D
	L	(3X)	
	M4*18	(3X)	S3

STEP 13

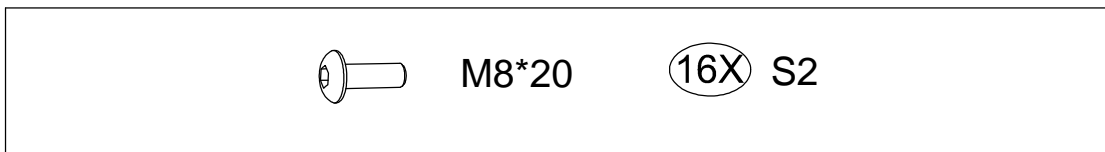
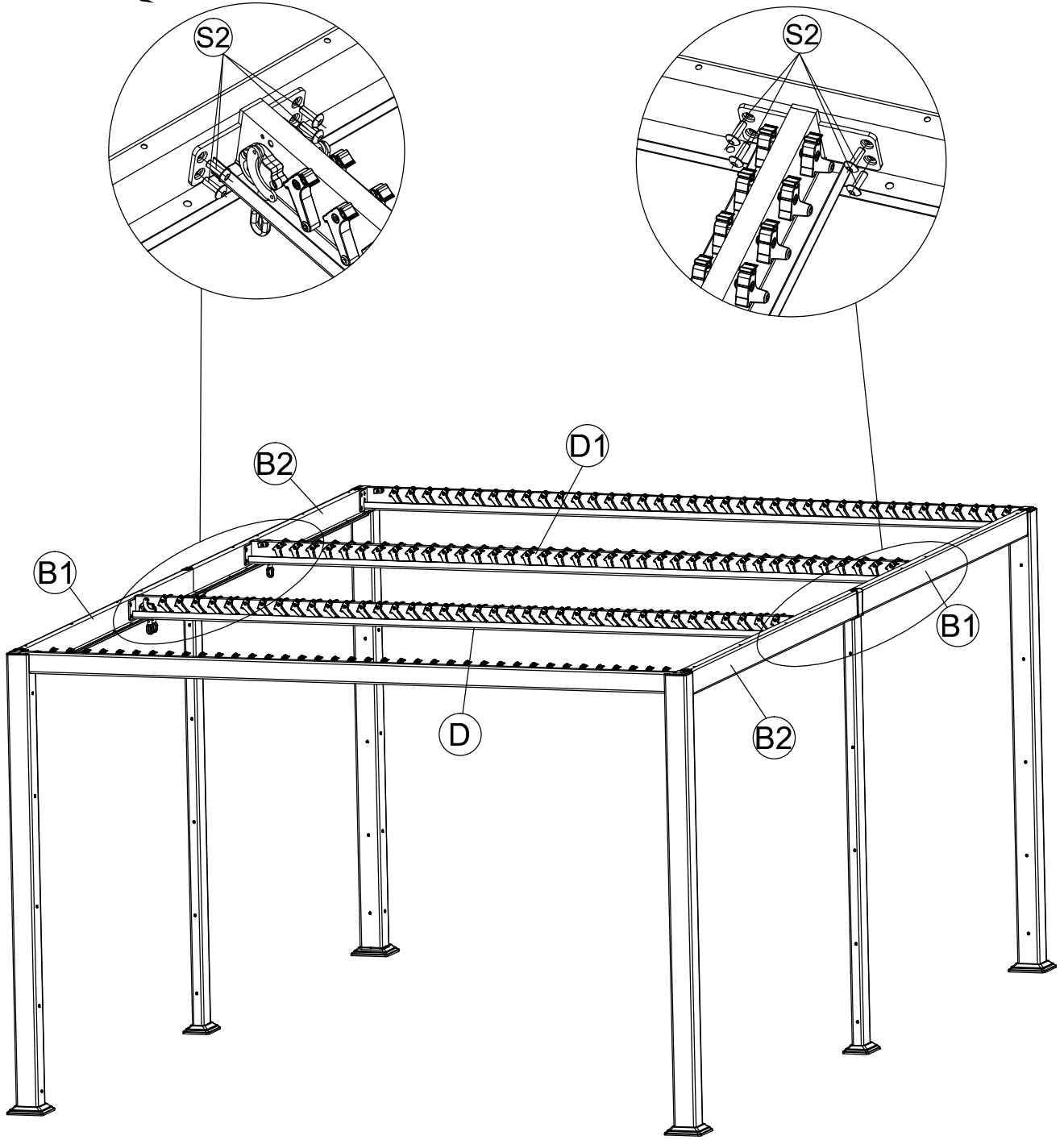

STEP 14

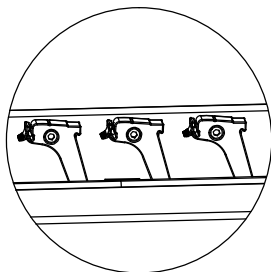
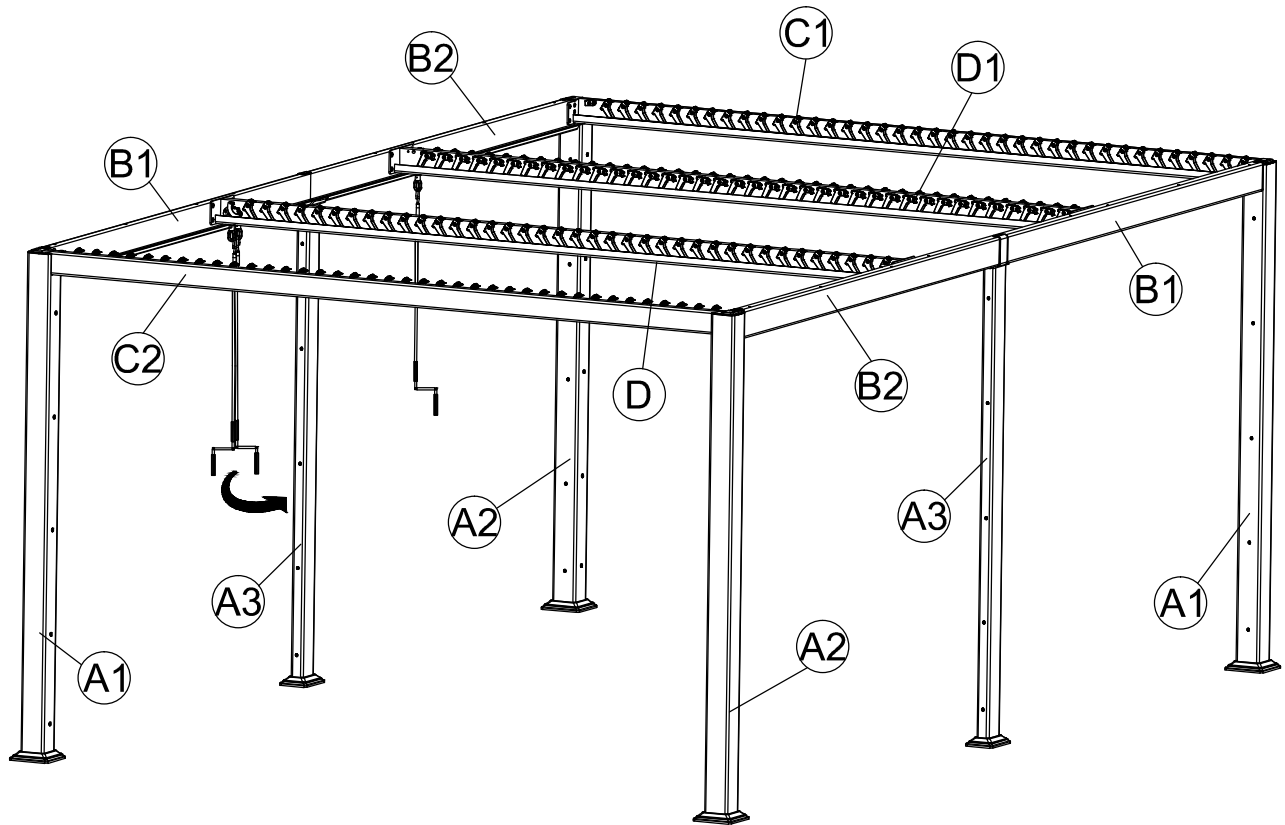

1

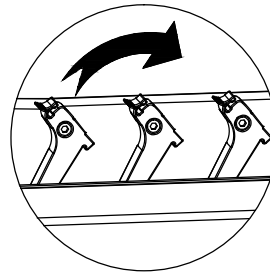
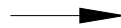

2

Turn the position from picture 1 to picture 2 first, then assemble the shutter.



(1X) R

STEP 15

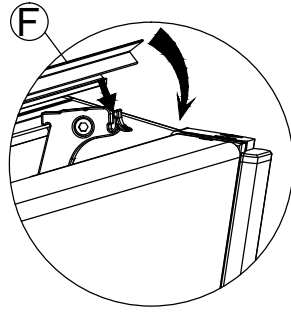

Step15-2

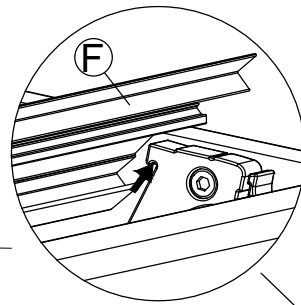

Step15-1

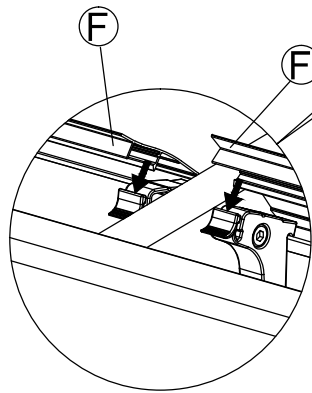
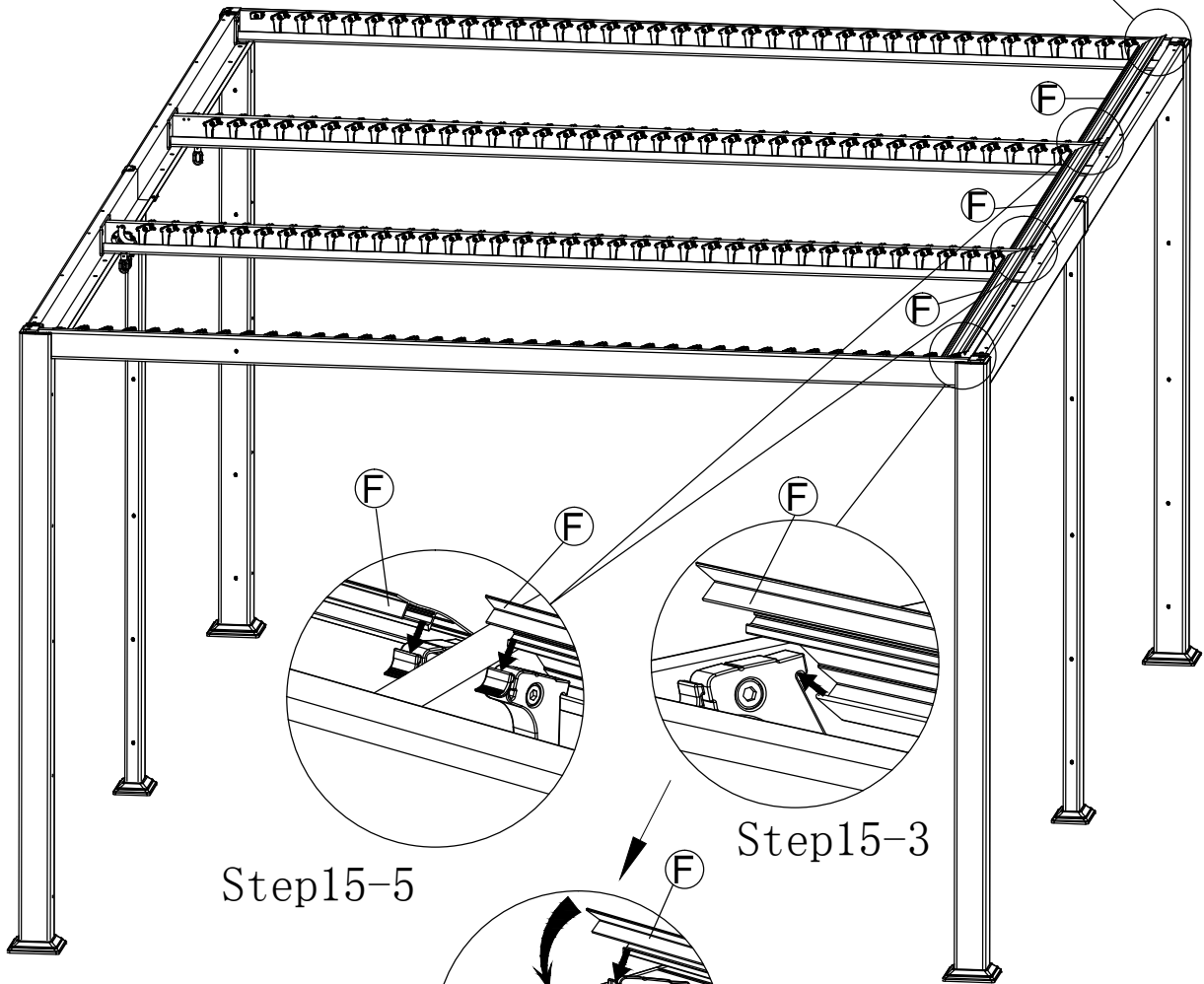

Step15-5

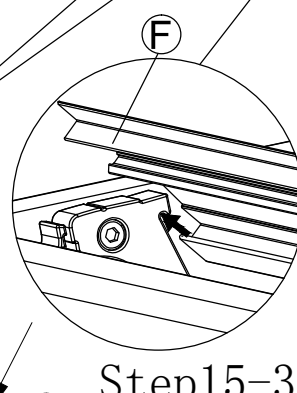

Step15-3

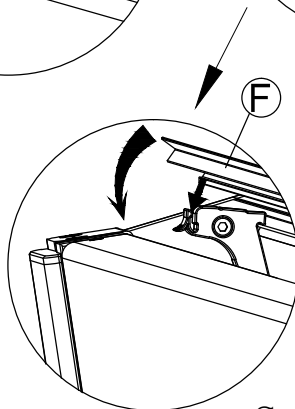

Step15-4

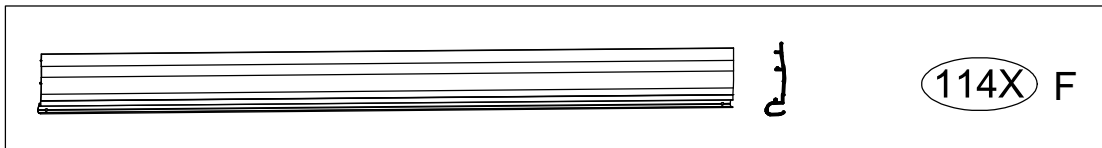

STEP 16

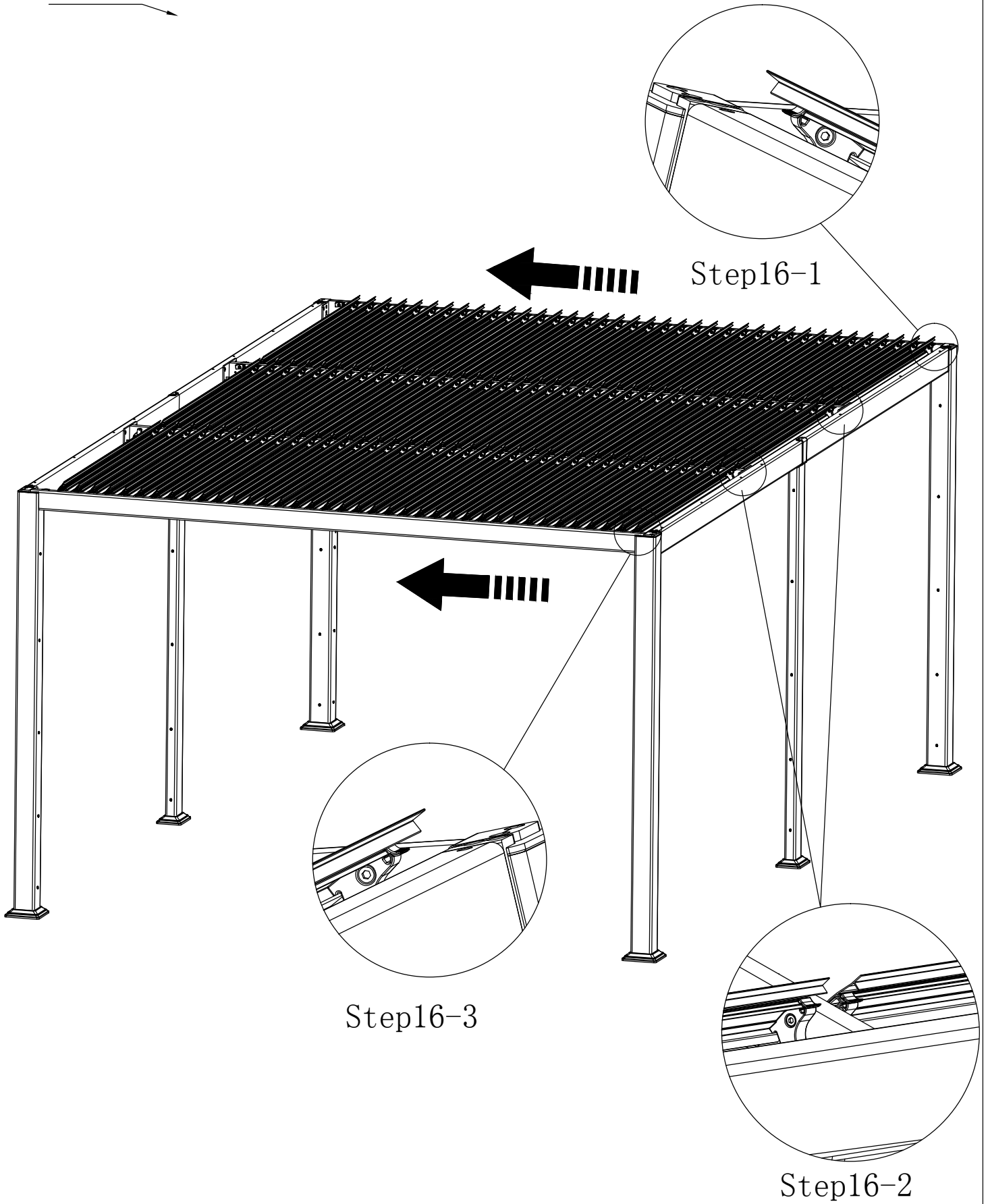

STEP 17

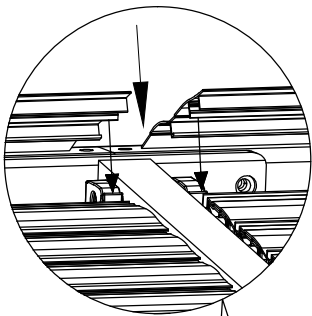

Step17-2

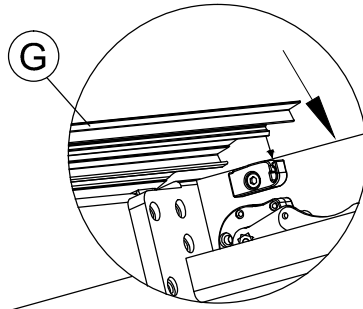

Step17-1

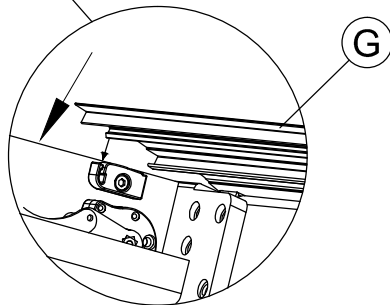
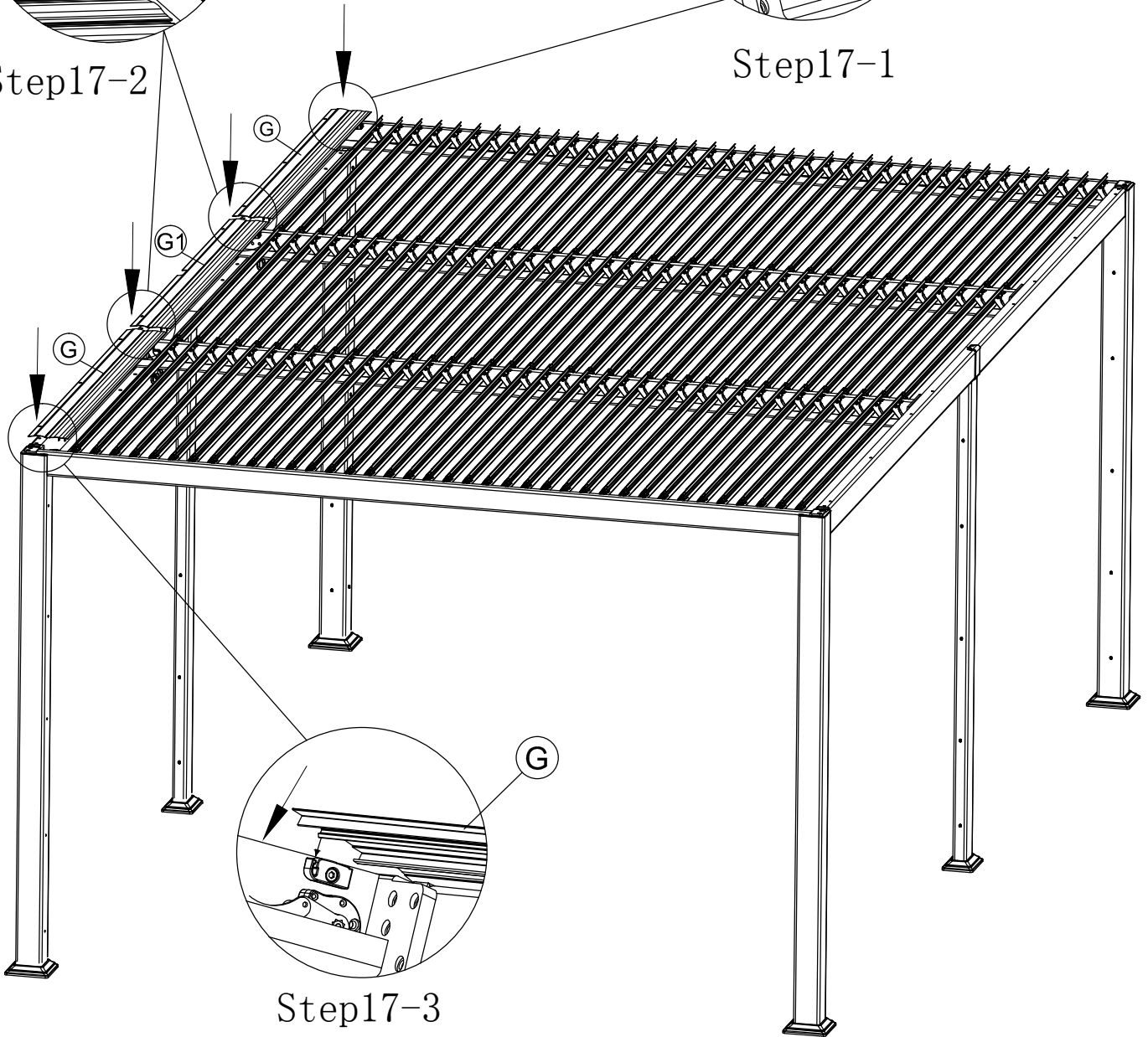

Step17-3

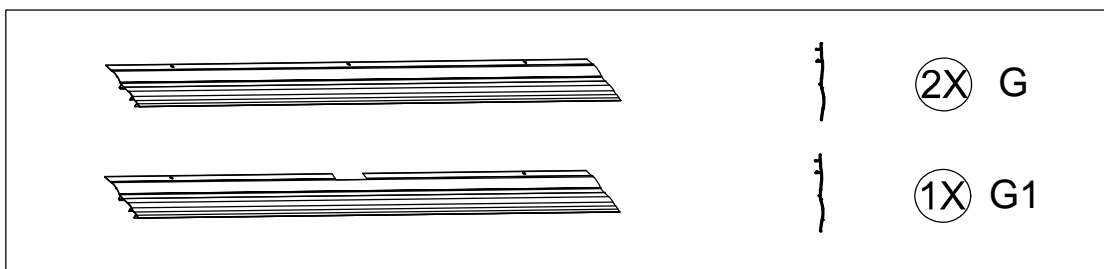

STEP 18

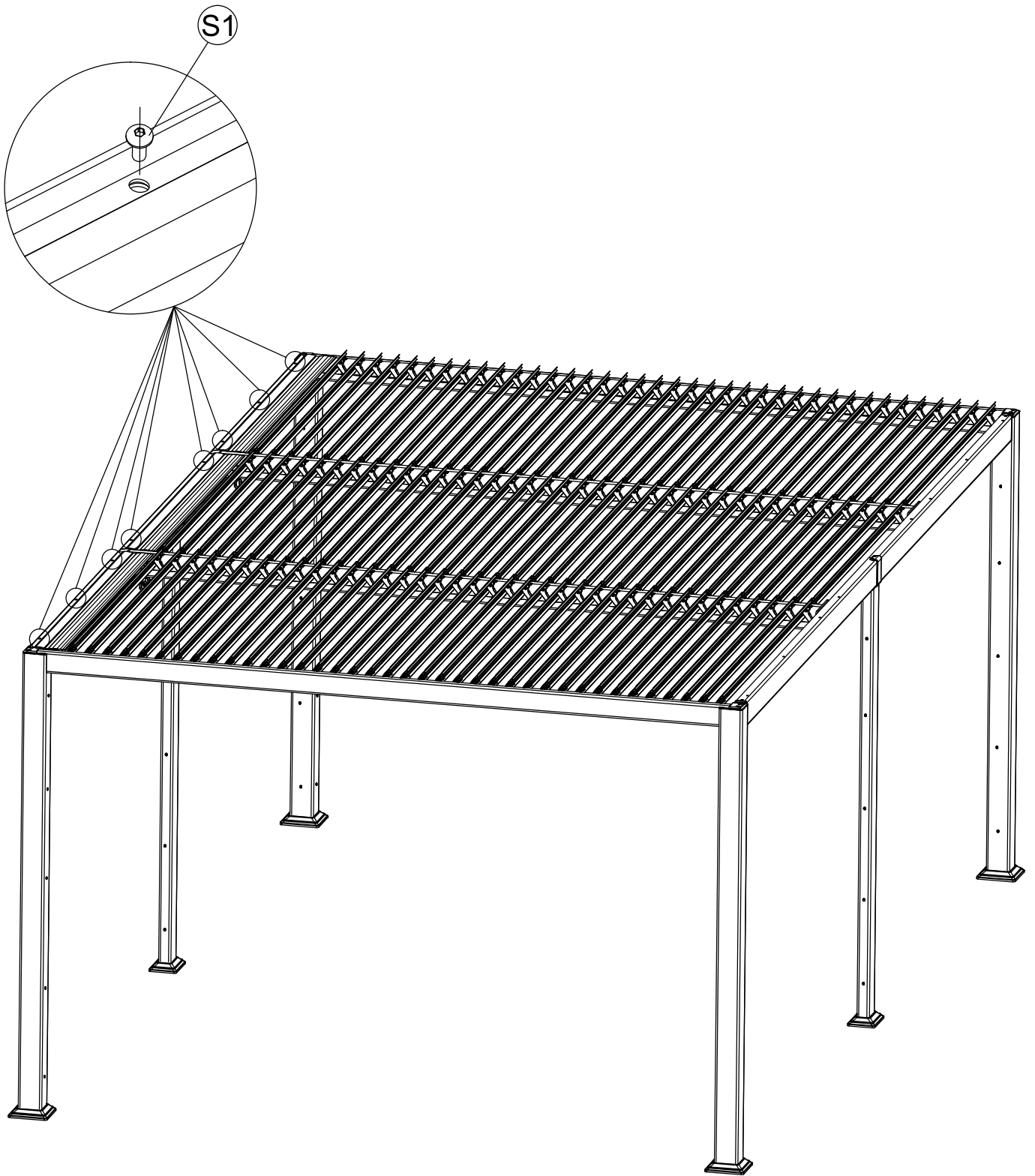

	M6*15	8X S1
---	-------	--------------

STEP 19

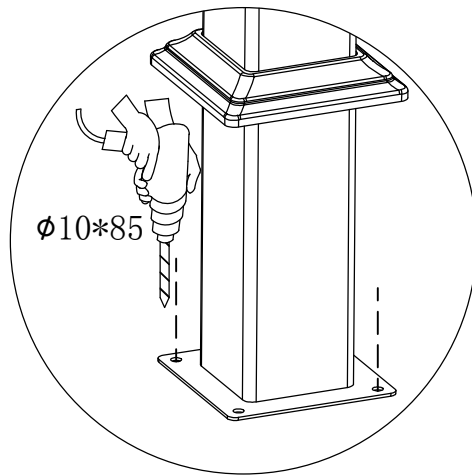
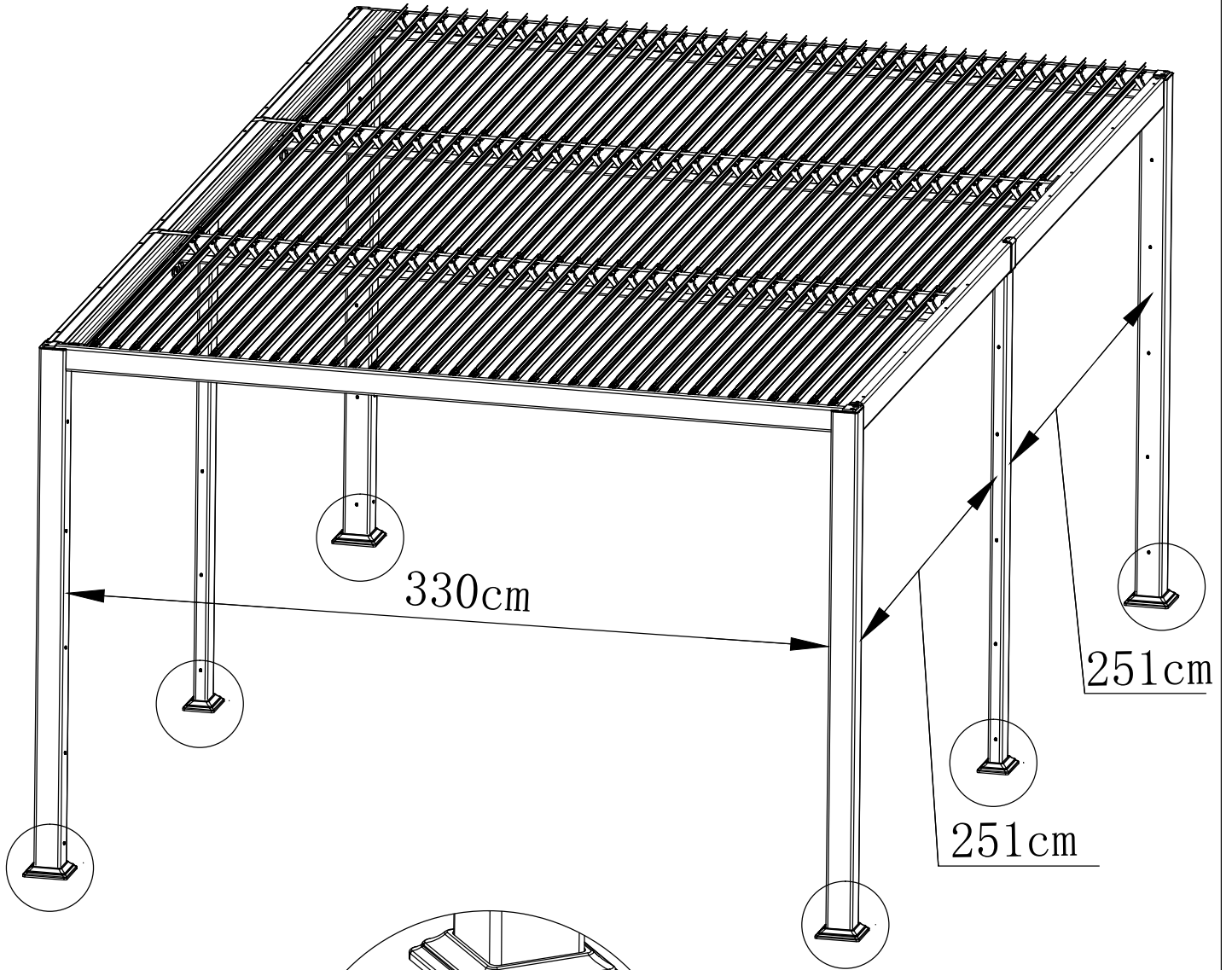

STEP 20

