

ASSEMBLY ISTRUCTIONS FOR PICNIC TABLES

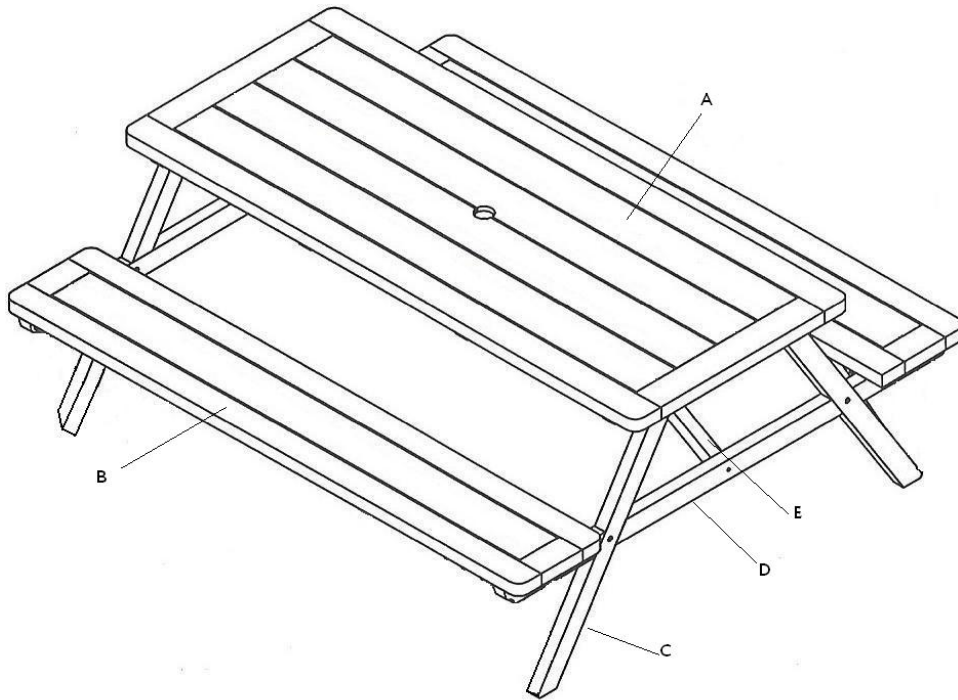

Thank you for purchasing the Sherwood picnic table.

SAFETY NOTE:

READ INSTRUCTIONS IN FULL BEFORE COMMENCING ASSEMBLY.

This table is very heavy and TWO PEOPLE are required to assemble and lift the table.

ALWAYS LIFT the table while moving. DO NOT DRAG the table as it may damage the legs.

INFORMATION ABOUT YOUR PICNIC TABLE:

The table is available in two size options: 1.4m or 1.8m.

Your table is made of FSC certified pine. The timber has been impregnated to protect your furniture against rot, mould, as well as insects (larva). The timber is kiln dried and pre-treated to category 3, giving a 10-year plus life span. As part of the weathering process cracks will appear, this is the normal behavior of the timber and the furniture is designed with this in mind with its strength and durability remaining unaffected.

MAINTENANCE:

It is recommended to regularly sweep dust and remove any stains. The table can be cleaned using soapy water and a stiff brush. Allow the timber to dry before applying any preservative. More severe stains, such as bird droppings or mould, can be removed by using a timber cleaner. Alternatively a medium grit sandpaper can be used.

It is strongly advised to treat your furniture annually with a good quality softwood timber preservative. Otherwise the timber will rot.

COMPONENTS CHECK LIST:

Parts	Code	Quantity	√
• Table top	A	1	<input type="checkbox"/>
• Table seats	B	2	<input type="checkbox"/>
• Legs	C	4	<input type="checkbox"/>
• Cross bars	D	2	<input type="checkbox"/>
• Table top supports	E	2	<input type="checkbox"/>
• 8 x 50 mm Allen bolts	F	16	<input type="checkbox"/>
• Allen key	G	1	<input type="checkbox"/>

IMPORTANT:

Although the size and design of purchased picnic table may differ from the one shown on the picture, the steps in the assembly process are identical for all the picnic tables.

STEP 1: LEGS ASSEMBLY

Place the table top up side down on a smooth, flat surface (for example on the box in which this product was supplied). Attach the legs using four Allen bolts.

DO NOT FULLY TIGHTEN THE BOLTS YET!

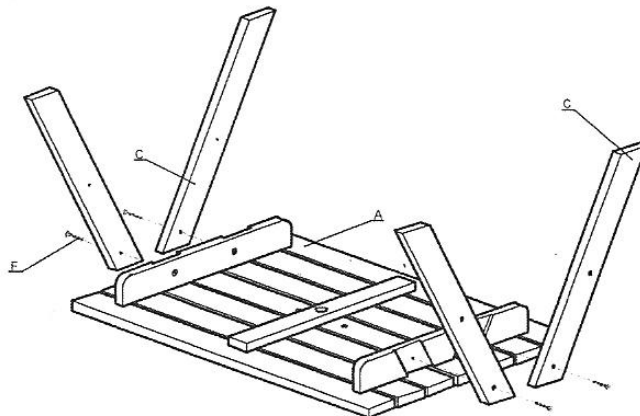

STEP 2: CROSS BARS ASSEMBLY

Attach the cross bars to the legs using four Allen bolts.

DO NOT FULLY TIGHTEN THE BOLTS YET!

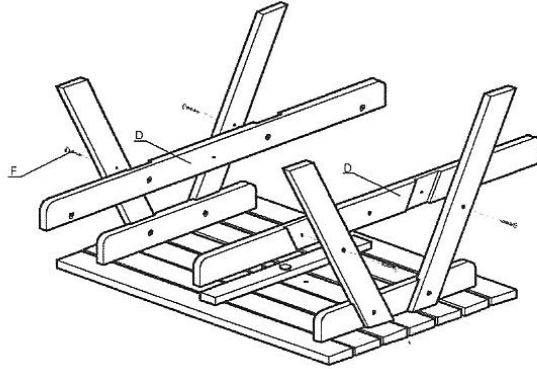

STEP 3: TABLE TOP SUPPORTS ASSEMBLY

Attach the table top supports as shown on the picture using four Allen bolts.

DO NOT FULLY TIGHTEN THE BOLTS YET!

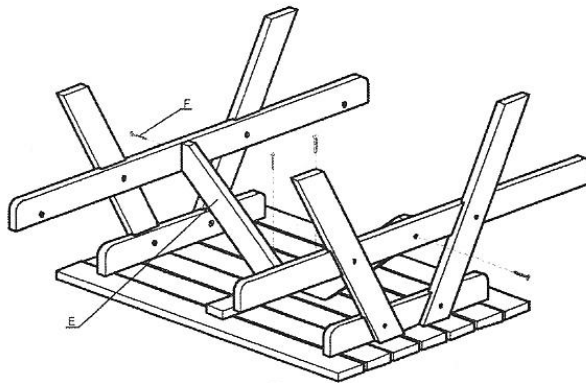

STEP 4: TABLE SEATS ASSEMBLY

Attach the seats to the cross bars using four Allen bolts. Tighten clockwise using the Allen key supplied.

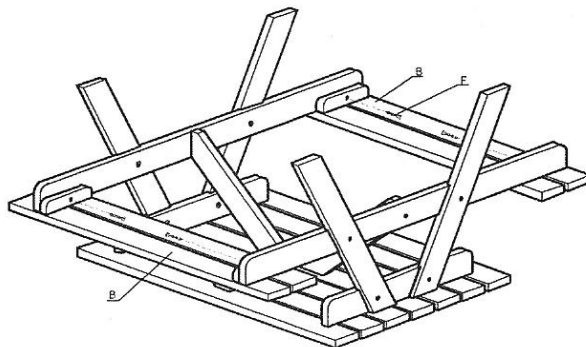

STEP 5: TIGHTEN ALL BOLTS

You can now fully tighten all the bolts using the Allen key supplied. NEVER OVERTIGHTEN BOLTS OR DAMAGE MAY OCCUR!

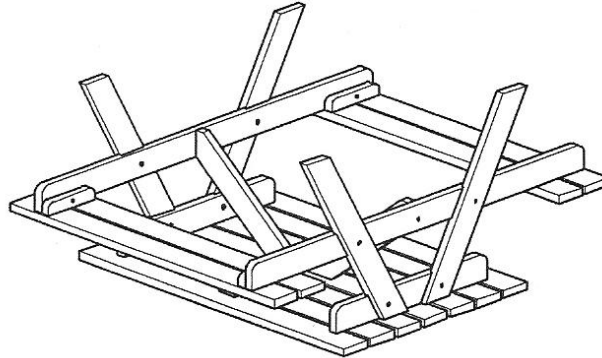

STEP 6: TURN TABLE UPRIGHT

Turn the table to the upright position however please remember that the product is very heavy and TWO PEOPLE ARE REQUIRED TO TURN THE TABLE TO THE UPRIGHT POSITION otherwise you may damage the legs.

Congratulations! The assembly process is now complete.

Please retain these assembly instructions for future reference.